

**GENERAL DESCRIPTION**

The L1084 is a positive and low dropout three-terminal voltage regulator with 5A output current capability. This device is designed for use in low voltage applications that offers lower dropout voltage and faster transient response.

This device is fully protected against over current faults, over temperature operation, reversed input polarity, reversed lead insertion, transient voltage spike ...etc.

On-Chips trimming the reference voltage to 1% and features the low dropout of maximum 1.45 volts.

The L1084 Series regulators are available in the popular industry standard TO-220, TO-263 and TO-252 packages.

**FEATURES**

- Very easy to use, it requires only two external resistors to set the output voltage
- Low dropout voltage: 1.2V typical at up to 5A
- Low ground current
- Fast transient response
- Current & thermal limiting
- Line regulation: 0.5% typical
- Load regulation: 0.5% typical
- TO-220, TO-263 and TO-252 packages

**APPLICATIONS**

- High current microprocessor supplies
- Low voltage logic supply
- Powering VGA & sound card
- Portable instrumentation
- Constant current regulator
- Post regulator for switching power supply

**TYPICAL APPLICATION**

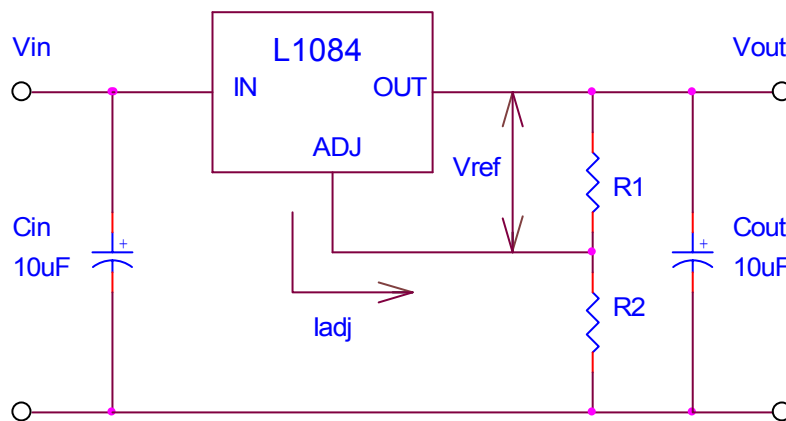

$$V_o = V_{ref} (1 + R_2/R_1) + I_{adj} \times R_2$$

1. Cin needed if device is far from filter capacitors.
2. Cout required for stability.

**- Basic Adjustable Regulator Circuit -**

**ABSOLUTE MAXIMUM RATINGS**

● Maximum Supply Voltage	7V	● Operating Junction Temperature Range	0 to 125 °C	
● Power Dissipation	Internally Limited		● Storage Temperature Range	-40 to 150 °C
● Thermal Resistance Junction to Case, $\theta_{JC}$	2.5 °C/W		● Lead Temperature (Soldering, 10 Seconds)	260 °C
● Thermal Resistance Junction to Ambient, $\theta_{JA}$				
TO-220	50 °C/W			
TO-263	60 °C/W			
TO-252	70 °C/W			

**ELECTRICAL CHARACTERISTICS** (Unless otherwise specified,  $T_A = 25\text{ °C}$ .)

Parameter	Symbol	Test Conditions	Typical	Limits
Reference Voltage	$V_{REF}$	$V_{IN} = 5V, I_{OUT} = 10mA$	1.25V	1.23V <sub>Min</sub> 1.27V <sub>Max</sub>
Dropout Voltage	$V_D$	$\Delta V_{REF} = 1\%, I_{OUT} = 5A$	1.2V	1.45V
Line Regulation	$REG_{(LINE)}$	$(V_{OUT} + 1.5V) \leq V_{IN} \leq 7V, I_{OUT} = 10mA$	0.5%	2%
Load Regulation	$REG_{(LOAD)}$	$(V_{IN} - V_{OUT}) = 3V, 10mA \leq I_{OUT} \leq 5A$	0.5%	2.5%
Minimum Load Current	$I_O$	$1.5V \leq (V_{IN} - V_{OUT}) \leq 5.75V$	10mA	
Adjust Pin Current	$I_{ADJ}$		55 $\mu$ A	100 $\mu$ A
Current Limit	$I_{CL}$	$V_{IN} - V_{OUT} = 2V$	7.5A	5.0A (Min)
RMS Output Noise	$V_N$		0.003% of $V_{OUT}$	
Ripple Rejection Ratio	$R_A$	$f = 120Hz, C_{ADJ} = 22\mu F$ for ADJ pin, $V_{IN} = 5V, I_{OUT} = 5A$	72dB	60dB (Min)

**DEVICE SELECTION GUIDE**

Device	L1084D	L1084S	L1084S3	L1084T
Package	TO-252	TO-263 (2-Lead)	TO-263 (3-Lead)	TO-220
Marking	L1084D	L1084S	L1084S3	L1084T

Typical Performance Characteristics

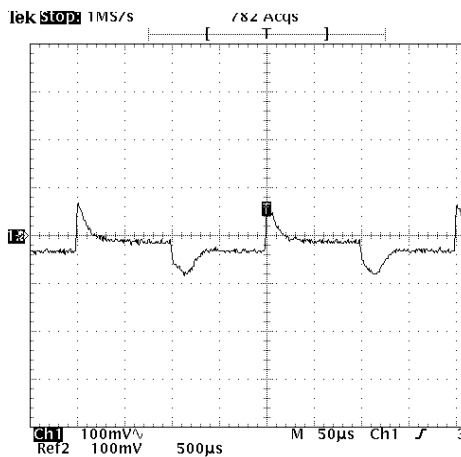
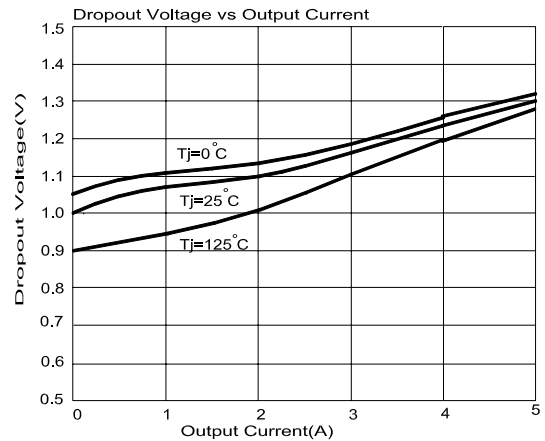
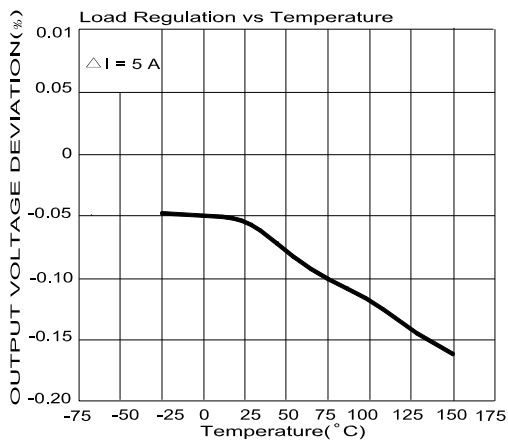
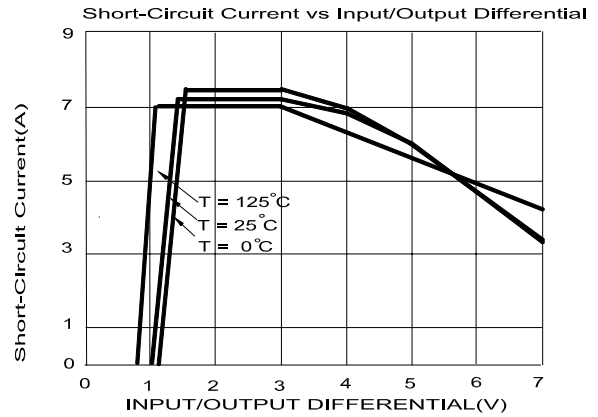
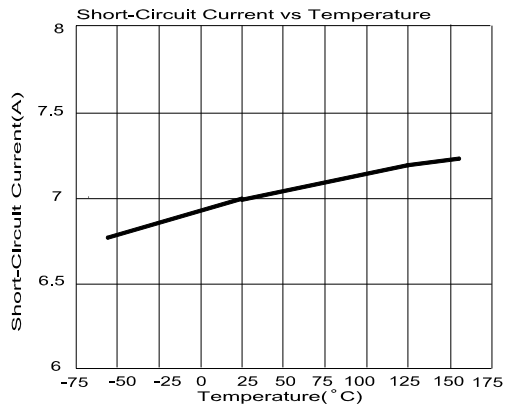

Vout=3.3V, Vin=5V, Iout=105mA/5A

Cin=10 µ F, Cout=10 µ F

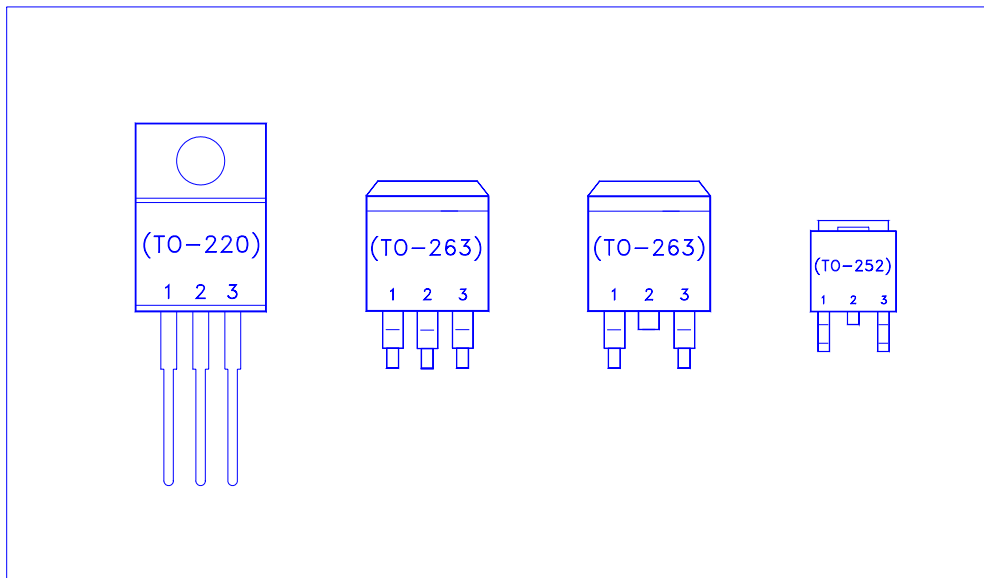
**PIN CONFIGURATIONS**

Pin #	Function
1	Adjust
2	Output
3	Input

**Note: TAB is Output Pin**

**TO-263 (D<sup>2</sup>PAK) MECHANICAL DATA**

Dimension	mm			Dimension	mm		
	Min.	Typ.	Max.		Min.	Typ.	Max.
A	14.5	15	15.8	H	1.0	1.5	1.8
B	4.2		4.7	I	9.8		10.3
C	1.20		1.35	J		6.5	
D		2.8		K		1.5	
E	0.3	0.4	0.5	L	0.7		1.4
F	-0.102		0.203	M	4.83	5.08	5.33
G	8.5	9	9.5	N			

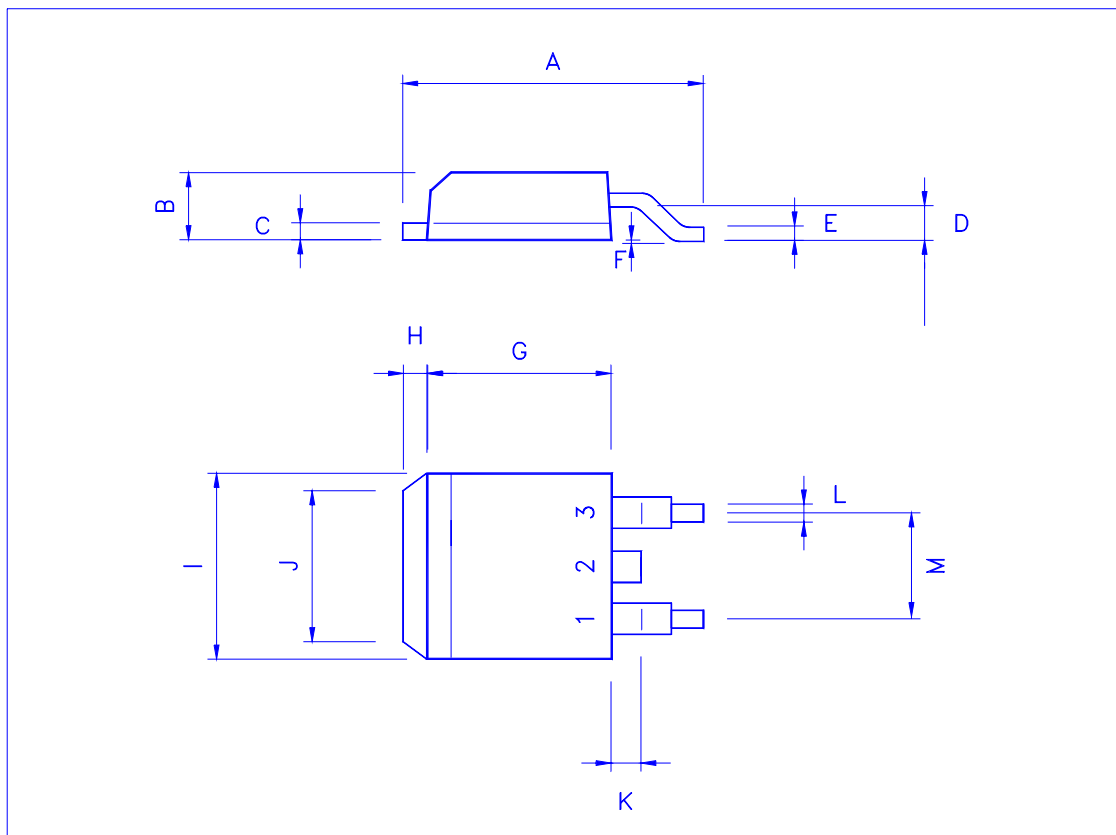

**TO-263 (D<sup>2</sup>PAK) MECHANICAL DATA**

Dimension	mm			Dimension	mm		
	Min.	Typ.	Max.		Min.	Typ.	Max.
A	14.5	15	15.8	H	1.0	1.5	1.8
B	4.2		4.7	I	9.8		10.3
C	1.20		1.35	J		6.5	
D		2.8		K		1.5	
E	0.3	0.4	0.5	L	0.7		1.4
F	-0.102		0.203	M	4.83	5.08	5.33
G	8.5	9	9.5	N			

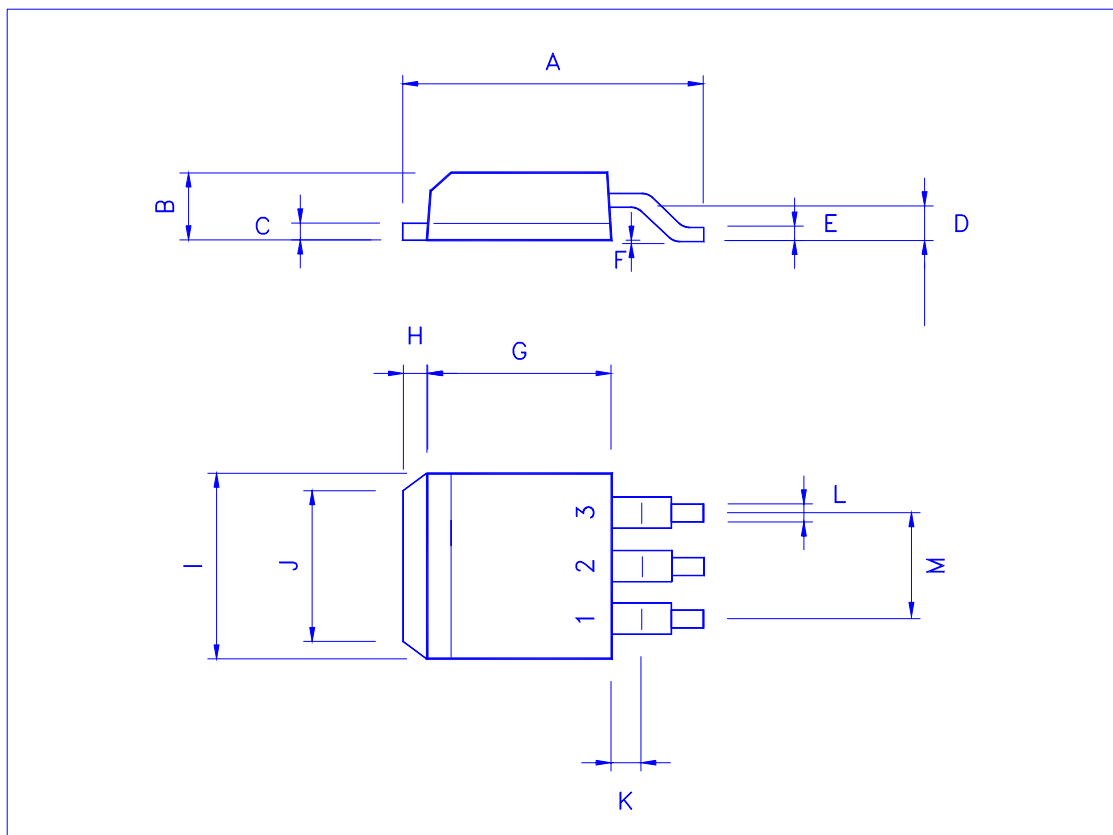

**TO-220 (3-Lead) MECHANICAL DATA**

Dimension	mm			Dimension	mm		
	Min.	Typ.	Max.		Min.	Typ.	Max.
A	9.78	10.16	10.54	H	2.4	2.54	2.68
B	2.61	2.74	2.87	I	1.19	1.27	1.35
C		20		J	4.4	4.6	4.8
D	28.5	28.9	29.3	K	1.14	1.27	1.4
E	14.6	15.0	15.4	L	2.3	2.6	2.9
F	8.4	8.8	9.2	M	0.26	0.46	0.66
G	0.72	0.8	0.88	N		7°	

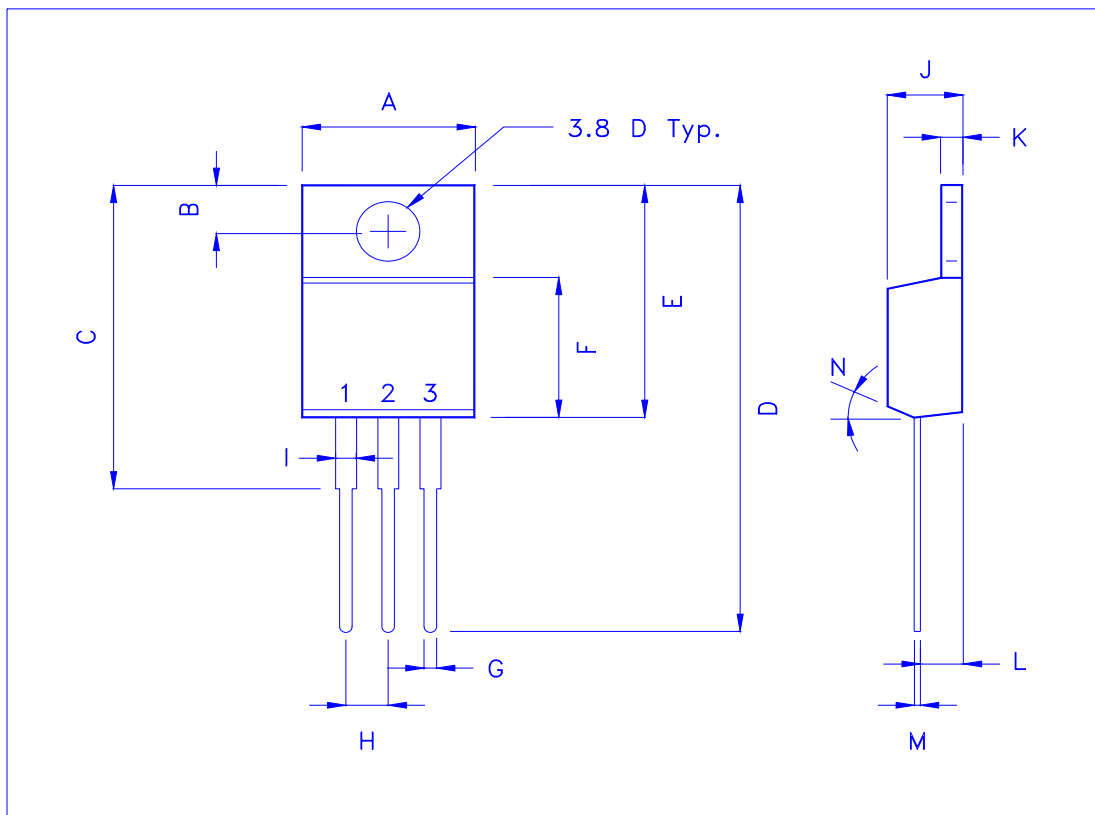

**TO-252 (DPAK) MECHANICAL DATA**

Dimension	mm			Dimension	mm		
	Min.	Typ.	Max.		Min.	Typ.	Max.
A	9.35		10.1	H		0.8	
B	2.2		2.4	I	6.4		6.6
C	0.48		0.6	J	5.2		5.4
D	0.89		1.5	K	0.6		1
E	0.45		0.6	L	0.64		0.9
F	0.03		0.23	M	4.4		4.6
G	6		6.2	N			

